

**HJ COOPER** By

**Rinnai**

# Owner and installer guide

## Mains pressure indoor stainless steel cylinders

**Models:** HJ Cooper mains pressure premium duplex stainless steel cylinders ('MS' electric prewired series)



**Hello installer**

Please leave this guide with the home owner as it contains important safety and warranty information.

## Important:

Cylinders shall be installed in accordance with:

- Manufacturer's installation instructions
- Current AS/NZS 3000, AS/NZS 3500, and G12/AS1
- Local regulations and municipal building codes

Installation, servicing and repair shall be carried out only by authorised personnel.

Not suitable as a spa or swimming pool heater.

Owner, please retain this guide for future reference.  
Installer, please leave this guide with the owner.

### Warning

Improper installation, adjustment, alteration, service or maintenance can cause property damage, personal injury or loss of life.

The appliance is not to be used by persons (including children) with reduced physical, sensory or mental capabilities, or lack of experience and knowledge, unless they have been given supervision or instruction.

---

For more information about buying, using, and servicing of Rinnai appliances call: 0800 RINNAI (0800 746 624)

Rinnai New Zealand Limited  
105 Pavilion Drive, Mangere, Auckland  
PO Box 53177, Auckland Airport, Auckland 2150

Phone: (09) 257 3800  
Fax: (09) 257 3899  
Email: [info@rinnai.co.nz](mailto:info@rinnai.co.nz)  
Web: [www.rinnai.co.nz](http://www.rinnai.co.nz)  
[www.youtube.com/rinnainz](http://www.youtube.com/rinnainz)  
[www.facebook.com/rinnainz](http://www.facebook.com/rinnainz)

# contents:

About your cylinder .....	4
Maintenance and servicing .....	5
Troubleshooting .....	6

## **Installation**

Specification summary .....	8
Dimensions .....	9
Plumbing setup .....	10
Storage and delivery temperatures .....	11
Water quality .....	12
Electrical supply and connections .....	13
Valves and fittings .....	14
Commissioning .....	14
Limited warranty .....	15
Warranty examples in the real-world .....	18
Proof of purchase .....	19
Installer details .....	19

# About your cylinder

Water is heated by an electric element, or elements located in the cylinder. The temperature of the water is controlled by an automatic thermostat that is set by your installer, usually to 65 °C.



## Important

All cylinders have the potential to leak water. To minimise damage to other areas of your home, ensure that your cylinder has been installed with a drip tray—the person doing the installation is responsible for this.



\* Refer to the warranty terms and conditions in this guide for more information.

## Safety messages

- **Element cover**  
Do not remove the element cover as this will expose 230 V wiring and must only be removed by an authorised person.
- **Thermostat setting**  
Must only be adjusted by an electrician or other suitably qualified tradesperson.
- **Damaged components**  
If any component is damaged, it must be replaced by an authorised person using Rinnai replacement parts.
- **Child supervision**  
Children should be supervised to ensure they do not play with any part of the hot water system.
- **Hot pipe work**  
Care should be taken not to touch the pipe work from the cylinder as this could be very hot.

## Safety devices

Your cylinder is fitted with a:

- Temperature & Pressure and Relief (TPR) valve that ensures the water remains at a safe pressure and temperature.
- Automatic thermostat to maintain water temperature.
- Temperature override cutout for heating element.

In the case of a standard cylinder (not installed in a solar application), the operation of the thermal cutout can indicate a dangerous situation. Do not reset the thermal cutout until the water heater has been serviced by a qualified person.

Do not operate the system unless all the safety devices are fitted and are in working order. It is also important that you do not tamper or remove any of these devices.

## Cylinder thermostat setting

To meet the New Zealand Building Code requirement<sup>1</sup> to disinfect water for legionella bacteria<sup>2</sup>, the cylinder thermostat has been set to 65 °C.

## Turning the cylinder on/off

If you plan to be away for a few nights we suggest you leave the system switched on. If it is necessary to switch it off, when switching back on, remember that the cylinder will take time to heat back up again.

## Draining and filling the system

This normally occurs during installation or servicing and must be carried out by an authorised person.

## Installation by a licensed tradesperson

Only a licensed tradesperson can install, adjust, maintain, and service this water heater. Any work carried out by a non-licensed tradesperson is illegal and will void any warranty.

<sup>1</sup> Clause G12.3.9, Acceptable Solution G12/AS1 6.14.3

<sup>2</sup> Legionella is a bacterium that can cause Legionnaires' disease—a severe form of pneumonia



# Maintenance and servicing



Hot water systems, like cars, require regular maintenance and servicing. To ensure longevity of your cylinder we recommend the following.

Period	What needs to be done
Every six months	TPR (temperature & pressure relief) valve—operate the easing gear
Year five	Inspection and service of the entire hot water system, including the element*
Every 24 months after year five	Inspection and service of the entire hot water system, including the element*

\* In hard water areas the element(s) must be periodically descaled. To do this the unit must be drained and the element(s) removed.

## TPR valve

This valve is located near the top of the cylinder and is essential for safe operation. The TPR valve works by automatically venting hot water if the temperature or pressure of the water in the cylinder gets too high.

Every six months operate the easing gear to remove lime deposits and to check that it is not blocked. As this will discharge hot water, ensure no one is near the drain line.



Failure to operate the relief valve easing gear at least once every six months may result in the water heater exploding. Continuous leakage of water from the valve may indicate a problem.

It is important that you raise and lower the easing gear gently. During the operation, if the valve does not discharge water when the easing gear is lifted, or does not seal again when closed, arrange for an authorised person to come and inspect the system immediately.



During servicing of your cylinder the TPR valve needs to be checked and/or replaced. This needs to be done by an authorised person at intervals not exceeding five years, or more frequently in areas where the water is classified as hard.

A TPR valve must not be replaced with one that has a higher pressure rating than that specified for the cylinder.

## Maintenance and servicing

Rinnai has a maintenance, service, and spare parts network with personnel who are fully trained and equipped to give the best advice on your Rinnai product. Regular maintenance and servicing is not covered by the Rinnai warranty.

For help locating a service person in your area call 0800 RINNAI (0800 746 624).

TPR position - top of cylinder



How to operate the easing gear

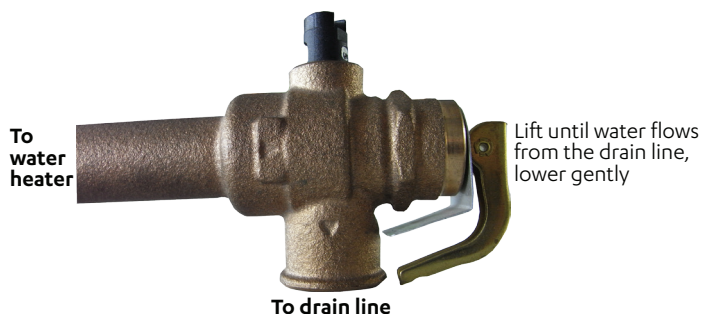

# Troubleshooting

Do not attempt to carry out any work other than that mentioned in this troubleshooting section. If you have any other faults or problems, please contact your installer, or contact Rinnai.

<b>Problem</b>	<b>Possible solution</b>
Lack of hot water or no hot water	<p><b>Is there electricity supply to the cylinder?</b></p> <p>Check that the isolating switch marked 'hot water' or 'water heater', at the meter box, is switched on. Also check any isolating switches near the water heater are switched on.</p> <p>Check the fuse or circuit breaker marked 'hot water' or 'water heater' at the meter box. Repeated failure of the fuse or tripping of the circuit breaker indicates a fault, which must be investigated by an authorised tradesperson.</p> <p>Most hot water cylinders are controlled at peak times by your electricity supplier via a ripple relay. Contact your electricity supplier to determine if there have been any issues with the power supply.</p>
Lack of hot water or no hot water	<p><b>Are you using more hot water than you think?</b></p> <p>Often you don't realise how much water is actually being used. This applies especially when showering. Typical flow rates for showers is approximately 8-10 litres per minute. Conduct a simple experiment by placing a measured bucket under your shower for ten seconds and multiply by six to determine the amount of water produced over a minute. If your result is significantly more than the rates mentioned you may want to consider installing a low flow shower rose—available at all good plumbing stores.</p>
Lack of hot water or no hot water	<p><b>Cold water relief valve discharging continuously?</b></p> <p>It is normal for the cold water relief valve to discharge a small quantity of water through the drain line. If water is discharging continuously there may be a fault with one of the valves, contact the installer to discuss.</p>
Water is too hot	<p>If possible check the temperature of the water coming out of a hot water tap with a thermometer. If it is higher than 55 °C then this indicates a problem with your system—contact an electrician for advice.</p>
High electricity bills	<p>If you think your electricity bill is too high, investigate the following:</p> <ul style="list-style-type: none"><li>• Has your electricity tariff changed?</li><li>• Is your cold water relief valve discharging continuously?</li><li>• Are you using more hot water than normal?</li><li>• Has there been any leaking hot water pipes, or taps?</li></ul>

# Installation

Installation, servicing and repair shall be carried out only by authorised personnel.

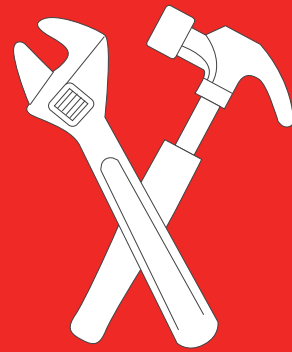

# Specification summary

## Suitability

- Indoor installations
- Main and low pressure systems
- Left or right hand plumbing connections
- Connection to open loop solar, or hot water heat pump systems.

Not suitable as a pool or spa heater.

The system should be located and arranged so as to achieve the closest proximity to water draw off points.

## Operating pressures

Maximum working pressure = 850 kPa

## Element

Incoloy 825 alloy sheath element positioned at the bottom of the tank, and midway if a twin element is purchased.

## Thermostat

The thermostat setting is between 60-70 °C. Maximum thermostat setting (in order to maintain the warranty) is 70 °C.

- **Standard cylinder**  
Robert Shaw 30 A contact thermostat, manually resettable at 85 °C (yellow dial).
- **Cylinder in a solar or hot water heat pump installation**  
Robert Shaw 30 A contact auto-reset thermostat (red dial).

## Weights

	empty	full
• 135 L:	26.5 kg	161.5 kg
• 180 L:	31.5 kg	211.5 kg
• 250 L:	41 kg	291 kg
• 300 L:	46.5 kg	346.5 kg

## Pressure limiting (reducing) valve

This water heater MUST be installed with a 500 kPa or less pressure limiting valve and appropriate cold water expansion valve.

## TPR valve

A temperature and pressure relief valve is supplied with the water heater and MUST be fitted. The TPR valve thread should be sealed with teflon tape, do not use paste and hemp. Use the spanner flats on the valve body to tighten, DO NOT use a wrench on the valve body.

The TPR valve must be fitted with a drain pipe to direct any water discharged to a visible point outside the property. The drain pipe must have a continuous fall and be at least the same size as the TPR valve outlet (1/2" BSP). Where the drain pipe exceeds three metres in length it is recommended an air break be provided within 300 mm of the TPR valve outlet. Where an air break is used it is recommended that the pipe size after the air break be increased to one size larger than the TPR valve. It must also be protected from freezing conditions.

**Protection against water: IPX1**

Incoloy 825 curved element



Incoloy 825 straight element



Robert Shaw 30 A thermostat - manually resettable (yellow dial)



Robert Shaw 30 A auto-reset thermostat (red dial)





# Dimensions

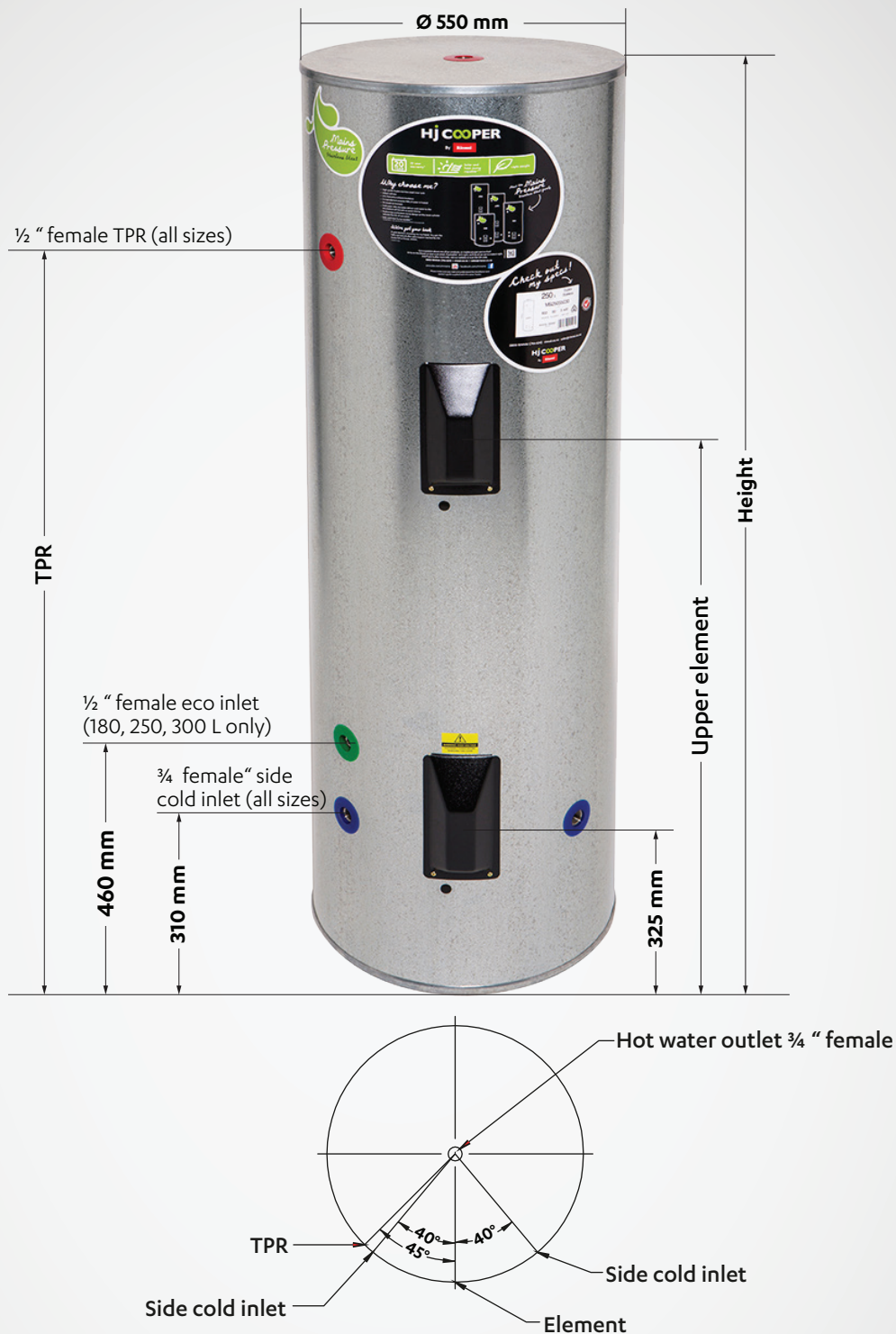

Tank size	Upper element	TPR	Height
135 L	N/A	690 mm	1023 mm
180 L	N/A	970 mm	1295 mm
250 L	1080 mm	1410 mm	1730 mm
300 L	1380 mm	1725 mm	2047 mm

# Plumbing setup

Cylinders should be installed in accordance with G12/AS1. For servicing and maintenance, please allow sufficient room for access to covers and valves.

## Plumbing setup for a mains pressure stainless steel cylinder

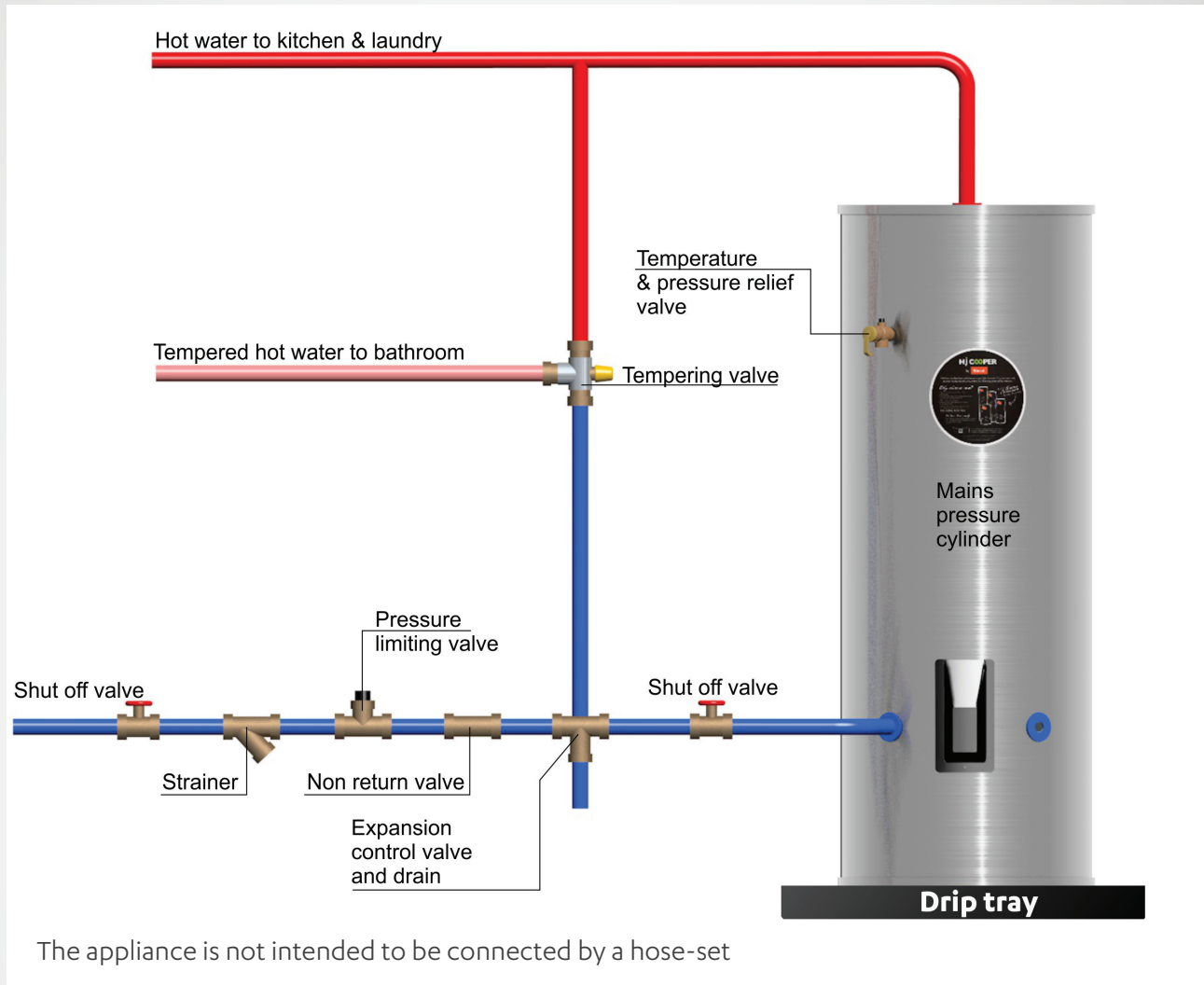

### Base requirements

Tanks should be installed on a flat level base of sufficient strength to support the weight of the water heater when full.

The water heater must also be suitably restrained against seismic activity, 'G12/AS1 Figure 14' details an acceptable method of restraint.

### Drip tray/catch pan (MUST be fitted)

The Rinnai warranty does not cover any consequential loss from leaks to the cylinder, so it's important a suitably drained drip tray/catch pan is fitted.

## Pipe work

It is the installer's responsibility to adequately size the distribution pipe work in a property to ensure sufficient performance from all outlet fittings. Water pipe sizing should be performed in accordance with AS/NZS 3500.4 and/or G12 AS1. Pipe sizing and valve selection must be performed to allow for the water supply pressure.

A drain off tap or line must be fitted to the inlet of the water heater.

All hot water pipe work should be insulated with polythene foam or equivalent insulation to optimise performance and energy efficiency.

To prevent damage to the water heater when attaching pipe clips or saddles to the jacket, it is recommended that self drilling screws with a maximum length of 12 mm are used. If drilling is required take extreme care not to penetrate the inner cylinder.

# Storage and delivery temperatures

## Storage temperature

To meet the New Zealand Building Code requirement<sup>1</sup> to disinfect water for legionella bacteria, the cylinder thermostat has been set to 65 °C.



Thermostat settings must only be adjusted by an electrician or other suitably qualified tradesperson. The access cover to the element and thermostat must only be removed by an electrician or other suitably qualified tradesperson.

## Sanitary fixtures delivery temperature

Water temperatures over 55 °C can cause severe scalds. Local regulations must be considered regarding temperature limitations of hot water supplied to areas used primarily for personal hygiene. The temperature is limited to 45 °C for early childhood centres, schools, nursing homes or similar facilities and 55 °C for all other buildings. To comply with these requirements, a temperature limiting device, such as a tempering or thermostatic mixing valve will be required on all installations.

<sup>1</sup> Clause G12.3.9, Acceptable Solution G12/AS1 6.14.3

# Water quality

HJ Cooper by Rinnai water heaters are manufactured to suit most NZ council water supplies. However some water supplies can have a detrimental effect on the water heater, its operation, and life expectancy.



## Pitting corrosion

The HJ Cooper by Rinnai stainless steel tanks are made from 2101 grade duplex stainless steel. This material has very good resistance to pitting corrosion with a Pitting Resistance Equivalent Number (PREN) of 26. This is a commonly used engineering indicator of corrosion resistance in stainless steel materials. The higher the PREN number the greater the resistance. In comparison 304 grade stainless, which is commonly used in domestic cookware and kitchen sinks, has a PREN number of 19. This means that HJ Cooper by Rinnai stainless steel tanks are highly resistant to pitting corrosion, but not completely immune from it.

Pitting corrosion may occur in the form of deposit attack if the water supply has a high percentage of dissolved solids present. It is advised in areas with a high concentration of dissolved solids in the water supply that consultation with water quality and filtration experts be undertaken.

## Hard water

Hard water (containing calcium carbonate) can cause scaling on hot surfaces. We recommend a water temperature of no more than 65 °C to minimise scale build-up. Scale reducing or water softening devices should be considered in hard water areas. The unit is not guaranteed against damage due to scaling.

Water quality outside the limits (as set down below) will void this warranty. Water quality tests must be carried out at the customer's own cost but Rinnai will reimburse any reasonable test costs where water quality is within the limits tabled.

## Water Quality and Impurity Limits

<b>TDS (Total Dissolved Solids)</b>	<b>Total Hardness CaCO<sub>3</sub></b>	<b>Dissolved (free) CO<sub>3</sub></b>	<b>pH</b>	<b>Langelier Index</b>
Up to 600 mg/L or ppm	Up to 200 mg/L or ppm	Up to 25 mg/L or ppm	6.5-8.5	Between -1.0-0.8

Most metropolitan water supplies fall within these limits. If you are unsure about water quality, please contact Rinnai and we will provide you with the details of an authorised agency able to test your water for compliance to Rinnai standards. If sludge or foreign matter is present in the water supply, a suitable filter should be incorporated in the water supply.

Some examples of water quality issues where water may need to be treated:

- Hard water (areas including Wanganui)
- Aggressive water (areas including Christchurch)
- Both hard and aggressive water (some bore water)

# Electrical supply and connections

The electrical connection must be carried out by a qualified person in accordance with NZ Electrical Regulations. The water heater must have the heating element connected to an independent, fused, AC 230 V 50 Hz power supply with an isolating switch installed at the switch board. Disconnect all power prior to installation and commissioning.

- The water heater must be filled with water prior to connection to the power supply
- Household wiring to the heater must be capable of withstanding the appliance load
- Fixed wiring must be protected from contact with the internal hot surface of the water heater

Electrical access is via a hole in the element cover for mounting with an approved electrical conduit gland. For entry to the element cover remove the two fixing screws.

Connect all LIVE, NEUTRAL and EARTH wires in accordance with the wiring diagram. Inspect and ensure all wiring links are secure prior to fixing the access cover and turning the power on.

To ensure the over-temperature and energy cutout is set press the 'reset' button on the thermostat.

The appliance is intended to be connected to cables of fixed wiring which has a cross-sectional area of 1.5 mm<sup>2</sup> - 2.5 mm<sup>2</sup>.

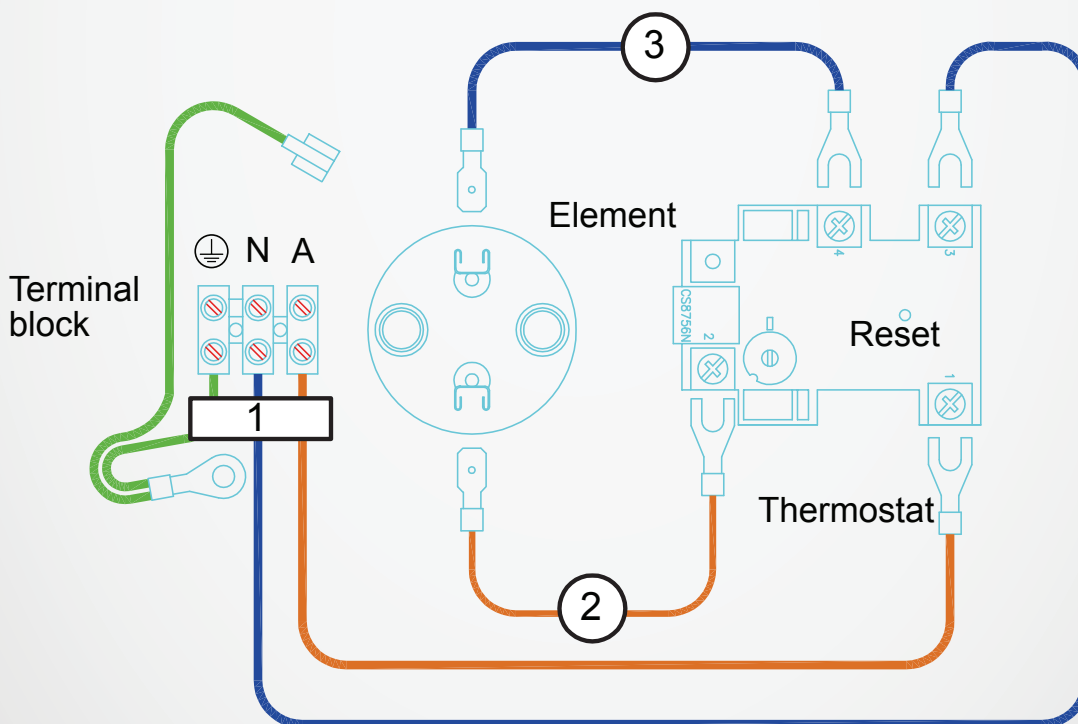

Wire No.	Description	Colour	Code
1	Wiring main loom R/Shaw assy.	Green/brown/blue	20197
2	Wire link brown R/Shaw assy.	Brown	20198
3	Wire link blue R/Shaw assy.	Blue	20199



## Valves and fittings

Valves with pressure ratings other than those listed in this manual must not be used.

### **Fittings supplied with the cylinder**

TPR valve, brass plugs, to plug unused connections, a key spanner, and the owner and installer guide are packaged in a plastic bag inside the element cover.

## Commissioning

Commissioning and draining activities must be carried out by an authorised person.

# 20 Year Limited Warranty

## Rinnai warranty summary table

This warranty applies to HJ Cooper by Rinnai Mains Pressure Stainless Steel cylinders only.

All terms of the warranty, subject to the conditions below, are effective from the date of installation. Proof of installation date will be required. Where the date of installation is not known or cannot be proven the warranty will commence one month after the date of manufacture—refer to the data label on the cylinder.

### Single residential application warranty

A residential application is defined as an installation where the water heater, with the thermostat set below 70 °C, delivers hot water to a single family residential dwelling, not used for commercial purposes<sup>1</sup>.

Component	Warranty period	Warranty
All components	Up to 1 year	Replace or repair free of charge the cylinder and/or part if it fails due to faulty manufacture.
Inner cylinder	Years 2-5 inclusive	Replace or repair free of charge* the inner cylinder if it fails due to faulty manufacture.
Inner cylinder	Years 6-10 inclusive	Replace or repair free of charge* the inner cylinder if it fails due to faulty manufacture. The cost of removal of the cylinder, re-installation, and labour costs are the responsibility of the owner.
Inner cylinder	Years 11-20 inclusive	Pro rata warranty. Inner cylinder is replaced at a cost that depends on the age of the cylinder at the time of failure, refer p. 18. The cost of removal of the cylinder, re-installation, and labour costs are the responsibility of the owner.

### Commercial application warranty

Component	Warranty period	Warranty
All components	Up to 1 year	Replace or repair free of charge the cylinder and/or part if it fails due to faulty manufacture.
Inner cylinder	Years 2-5 inclusive	Replace or repair free of charge* the inner cylinder if it fails due to faulty manufacture. The cost of removal of the cylinder, re-installation, and labour costs are the responsibility of the owner.

For constant use applications such as, but not limited to these, underfloor heating and circulating ring mains. The cylinder must be sized and installed according to written guidelines from Rinnai.

<sup>1</sup> Examples where a residential dwelling is used for commercial purposes; hair salon, catering kitchen, communal care facility etc. These installations would be considered commercial applications. An exception would be an accommodation business such as a motel, where the water heater serves the equivalent of a single family dwelling, this would be a residential application.

\* Except for certain travel and transport costs, refer to the 'Warranty terms and conditions' (9).

## General warranty terms

Rinnai reserves the right to make modifications and change specifications and its parts without notice.

For the purposes of the Consumer Guarantees Act 1993, Rinnai only guarantees the availability of repair facilities and spare parts for the express warranty periods recorded in the Rinnai warranty summary table.

If the cylinder is being acquired for personal, domestic or household use, this warranty does not limit any consumer rights or guarantees that may apply under the Consumer Guarantees Act 1993. If the product is being acquired for the purposes of a business, the provisions of the Consumer Guarantees Act 1993 do not apply and no other warranties (either express or implied by law) apart from those stated in this warranty apply.

## Warranty terms and conditions

1. All terms of this warranty are effective from the date of installation. The attending service person reserves the right to verify this date.
2. All Rinnai cylinders must be installed, commissioned, serviced, repaired and removed in accordance with the manufacturer's installation instructions, local regulations, and municipal building codes by persons authorised to do so.
3. All Rinnai cylinders must be operated and maintained in accordance with manufacturer's instructions.
4. The warranty applies only to the components supplied by Rinnai. It does not apply to components supplied by others, such as, but not limited to these, isolating valves, electrical switches, pipe work, electrical cables, and fuses.
5. Where the cylinder has not been sited in accordance with the installation instructions or installed such that normal service access is difficult, a service charge will apply. If at the discretion of the attending service person the installation is deemed illegal or access is dangerous, service will be refused. Any work required to gain reasonable access to the cylinder will be chargeable by the attending service person (for example, removal of cupboards, doors, walls, or the use of special equipment to move components, but not limited to these).
6. The cylinder warranty is for the period indicated in the summary table. Where the inner cylinder and/or part is replaced under warranty, the replacement cylinder and/or part will carry a new warranty.
7. Rinnai reserve the right to transfer functional components from defective water heaters if they are suitable.
8. Rinnai reserve the right to have the installed product returned to the factory for inspection.
9. Where the cylinder is installed outside the metropolitan area or further than 40 km from a Rinnai authorised service centre, travel costs shall be the owner's responsibility.
10. Rinnai reserves the right to replace the cylinder for another type if upon inspection it is deemed another cylinder of a different construction is more suitable.

## Warranty exclusions

The following exclusions may cause the warranty to become void and will result in a service charge and costs of parts (if required).

1. Accidental damage and acts of God.
2. Failure due to abuse or misuse, improper maintenance or improper storage.
3. Failure due to incorrect or unauthorised installations.
4. Failure or damage caused by alterations, service or repair work carried out by persons other than those authorised by Rinnai.
5. Where the cylinder has failed directly or indirectly as a result of poor water quality outside the limits specified.

<b>TDS (Total Dissolved Solids)</b>	<b>Total Hardness CaCO<sub>3</sub></b>	<b>Dissolved (free) CO<sub>3</sub></b>	<b>pH</b>	<b>Langelier Index</b>
Up to 600 mg/L or ppm	Up to 200 mg/L or ppm	Up to 25 mg/L or ppm	6.5-8.5	Between -1.0-0.8

6. Where it is found that there is no fault with the cylinder and the issue is related to the installation or is due to power failure.
7. Subject to any statutory provisions to the contrary, Rinnai does not accept:
  - a. liability for consequential damage or any incidental expenses resulting from any breach of the warranty,
  - b. claims for damage to building or any other consequential loss either directly or indirectly due to leaks or any other faults.

# Warranty examples in the real-world

We understand warranty information can be confusing. To help clarify what this means in the real-world we have developed some single residential application scenarios to clarify what would fall within warranty and what wouldn't.

Scenario	Age of part/ cylinder	Within warranty	
Faulty thermostat	10 months	Yes	All costs covered by Rinnai.
Faulty element	3 years	No	All costs covered by the owner.
Cylinder leaks as a result of a faulty inner cylinder and causes damage to carpets and flooring	11 months	Yes/No	Cost of cylinder replacement covered by Rinnai. Consequential loss, damage to carpets and flooring, is not <sup>1</sup> .
Inner cylinder fails	7 years	Yes	Cost of cylinder replacement covered by Rinnai. The cost of removal of the cylinder, re-installation, and labour costs are the responsibility of the owner.
Outer cylinder showing signs of corrosion	3 years	No	Only the inner cylinder is covered by warranty

## <sup>1</sup> Consequential losses

All cylinders are required to be installed with a drip tray, this is a mandatory requirement of the installation. If damage is caused by a leaking cylinder that has not been installed with a drip tray the owner can seek compensation through the installer or consider claiming on insurance.

## Pro rata warranty explanation and scenarios

Years 11-20 of the HJ Cooper by Rinnai Mains Pressure Stainless Steel cylinders are covered by a pro rata warranty where the replacement cost is reduced according to the age of the cylinder. This is calculated using the following formula.

Original purchase price x remaining warranty in years ÷ total warranty period of the cylinder.

### Scenario example 1

A warranty claim is approved where an inner cylinder fault is identified. The cylinder is 11 years old. Original purchase price was \$1000. The cylinder needs replacing at a cost of \$1200. The owner in this example would need to pay \$750 for the replacement cylinder **plus** labour and installation costs.

$$\begin{aligned} & \$1000 \text{ (orig. purchase price)} \times 9 \text{ (remaining warranty in years)} \div 20 \text{ (total warranty period of cylinder)} = \$450 \\ & \$1200 \text{ (replacement cost of cylinder)} - \$450 = \$750 \text{ (owner to pay*)} \end{aligned}$$

### Scenario example 2

A warranty claim is approved where an inner cylinder fault is identified. The cylinder is 18 years old. Original purchase price was \$1000. The tank needs replacing at a cost of \$1200. The owner in this example would need to pay \$1100 for the replacement cylinder **plus** labour and installation costs.

$$\begin{aligned} & \$1000 \text{ (orig. purchase price)} \times 2 \text{ (remaining warranty in years)} \div 20 \text{ (total warranty period of cylinder)} = \$100 \\ & \$1200 \text{ (replacement cost of cylinder)} - \$100 = \$1100 \text{ (owner to pay*)} \end{aligned}$$

\* Does not include labour or installation costs



# Proof of purchase

RECORD YOUR DETAILS  
OF PURCHASE BELOW:

ATTACH YOUR PROOF OF  
PURCHASE HERE:

Retailer: \_\_\_\_\_

Retailer address: \_\_\_\_\_

\_\_\_\_\_

Date of purchase: \_\_\_\_\_

Product details: \_\_\_\_\_

\_\_\_\_\_

\_\_\_\_\_

**Please keep these details in a safe place for future reference.**

# Installer details

Company name: \_\_\_\_\_

Installer name: \_\_\_\_\_

Address: \_\_\_\_\_

\_\_\_\_\_

Phone: \_\_\_\_\_ Mobile: \_\_\_\_\_

Signed: \_\_\_\_\_ Date: \_\_\_\_\_

\_\_\_\_\_



Experience our innovation

**Rinnai.co.nz** | **0800 746 624**

<http://www.youtube.com/rinnainz>

<http://www.facebook.com/rinnainz>