



Low pressure indoor copper cylinders

Owner and installer guide

Rinnai

Important

Cylinders shall be installed in accordance with:

- Manufacturer's installation instructions
- Current AS/NZS 3000, AS/NZS 3500, and G12/AS1

Installation, servicing and repair shall be carried out only by authorised personnel.

Not suitable as a spa or swimming pool heater.

- Owner, please retain this guide for future reference
- Installer, please leave this guide with the owner

Warning

Improper installation, adjustment, alteration, service and maintenance can cause property damage, personal injury or loss of life.

This appliance is not to be used by persons (including children) with reduced physical, sensory or mental capabilities, or lack of experience and knowledge, unless they have been given supervision or instruction.

For more information about buying, using, and servicing of Rinnai appliances call: 0800 RINNAI (0800 746 624).

Rinnai New Zealand Limited
105 Pavilion Drive, Mangere, Auckland
PO Box 53177, Auckland Airport, Auckland 2150

Phone: (09) 257-3800
Fax: (09) 257-3899
Email: info@rinnai.co.nz
Web: rinnai.co.nz
[youtube.com/rinnainz](https://www.youtube.com/rinnainz)
[facebook.com/rinnainz](https://www.facebook.com/rinnainz)

Contents

About your cylinder.....	4
Maintenance and servicing.....	4
Troubleshooting.....	6

Installation

Specification summary.....	8
Dimensions.....	9
Plumbing setup.....	11
Storage and delivery temperatures.....	12
Water quality.....	13
Electrical supply and connections.....	14
Valves and fittings.....	15
Commissioning.....	15
Limited Warranty.....	16
Warranty examples in the real-world.....	18
Proof of purchase.....	19
Installer details.....	19

About your cylinder



Important

All cylinders have the potential to leak water. To minimise damage to other areas of your home, ensure that your cylinder has been installed with a drip tray—the person doing the installation is responsible for this.



* Refer to the warranty terms and conditions in this guide for more information.

Safety messages

- **Element cover**
Do not remove the element cover as this will expose 230 V wiring and must only be removed by an authorised person.
- **Thermostat setting**
Must only be adjusted by an electrician or other suitably qualified tradesperson.
- **Damaged components**
If any component is damaged, it must be replaced by an authorised person using Rinnai replacement parts.
- **Child supervision**
Children should be supervised to ensure they do not play with any part of the hot water system.
- **Hot pipe work**
Care should be taken not to touch the pipe work from the cylinder as this could be very hot.

Safety devices

Your cylinder should have the following safety devices fitted.

- Valve vented systems
 - pressure reducing valve
 - pressure relief valve
 - cold water expansion valve
 - tempering valve
 - energy cutout thermostat
- Open vented systems
 - pressure reducing valve
 - tempering valve
 - energy cut-out thermostat
 - vent pipe

Do not operate the system unless all the safety devices are fitted and are in working order. It is also important that you do not tamper or remove any of these devices.

Your hot water system has an energy cutout thermostat. The operation of this thermal cut-out indicates a dangerous situation. Do not reset the thermal cutout until the cylinder has been serviced by an authorised person.

Cylinder thermostat setting

To meet the New Zealand Building Code requirement¹ to disinfect water for legionella bacteria², the thermostat has been set to 65 °C.

Turning the cylinder on/off

If you plan to be away for a few nights we suggest you leave the system switched on. If it is necessary to switch it off, when switching back on, remember that the cylinder will take time to heat back up again.

Draining and filling the system

This normally occurs during installation or servicing and must be carried out by an authorised person.

Installation by a licensed tradesperson

Only a licensed tradesperson can install, adjust, maintain, and service this water heater. Any work carried out by a non-licensed tradesperson is illegal and will void any warranty.

¹ Clause G12.3.9, Acceptable Solution G12/AS1 6.14.3

² Legionella is a bacterium that can cause Legionnaires' disease—a severe form of pneumonia

Maintenance and servicing

Hot water systems, like cars, require regular maintenance and servicing. To ensure longevity of your cylinder we recommend the following.



Period	What needs to be done
Year five	Inspection and service the entire hot water system, including element*
Every 24 months after year five	Inspection and service the entire hot water system, including element*

* In hard water areas the element(s) must be periodically descaled. To do this the cylinder must be drained and the element(s) removed

Rinnai has a maintenance, service, and spare parts network with personnel who are fully trained and equipped to give the best advice on your Rinnai product. Regular maintenance and servicing is not covered by the Rinnai warranty.

For help locating a service person in your area call 0800 RINNAI (0800 746 624).

Troubleshooting

Do not attempt to carry out any work other than that mentioned in this troubleshooting section. If you have any other faults or problems, please contact your installer, or contact Rinnai.

Problem	Possible solution
Lack of hot water or no hot water	<p>Is there electricity supply to the cylinder?</p> <p>Check that the isolating switch marked 'hot water' or 'water heater', at the meter box, is switched on. Also check any isolating switches near the water heater are switched on.</p> <p>Check the fuse or circuit breaker marked 'hot water' or 'water heater' at the meter box. Repeated failure of the fuse or tripping of the circuit breaker indicates a fault, which must be investigated by an authorised tradesperson.</p> <p>Most hot water cylinders are controlled at peak times by your electricity supplier via a ripple relay. Contact your electricity supplier to determine if there have been any issues with the power supply.</p>
Lack of hot water or no hot water	<p>Are you using more hot water than you think?</p> <p>Often you don't realise how much water is actually being used. This applies especially when showering. Typical flow rates for showers is approximately 8-10 litres per minute. Conduct a simple experiment by placing a measured bucket under your shower for ten seconds and multiply by six to determine the amount of water produced over a minute. If your result is significantly more than the rates mentioned you may want to consider installing a low flow shower rose—available at all good plumbing stores.</p>
Lack of hot water or no hot water	<p>Cold water relief valve discharging continuously?</p> <p>It is normal for the cold water relief valve to discharge a small quantity of water through the drain line. If water is discharging continuously there may be a fault with one of the valves, contact the installer to discuss.</p>
Water is too hot	<p>If possible check the temperature of the water coming out of a hot water tap with a thermometer. If it is higher than 55 °C then this indicates a problem with your system—contact an electrician for advice.</p>
High electricity bills	<p>If you think your electricity bill is too high, investigate the following:</p> <ul style="list-style-type: none">• Has your electricity tariff changed?• Is your cold water relief valve discharging continuously?• Are you using more hot water than normal?• Has there been any leaking hot water pipes, or taps?

Installation

Installation, servicing and repair shall be carried out only by authorised personnel.

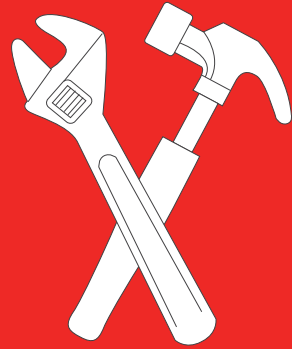

Specification summary

low pressure copper undersink

Suitability

- Low pressure indoor applications
- Left, right, or bottom plumbing connections

Not suitable as a pool or spa heater.

The system should be located and arranged so as to achieve the closest proximity to water draw off points.

Construction

- High grade copper inner cylinder
- Galvanised steel outer casing
- HCFC-free polyurethane foam insulation (ODP free)

Operating pressures

Maximum inlet pressure = 76 kPa

Maximum working pressure = 76 kPa

Element

Low watt density nickel plated copper, 1.25 " BSP boss.



Thermostat

7 " Cotherm probe 20 A over-temperature thermostat, manually resettable at 85 °C.



Weights (empty/full)

- 9 L: 7/16 kg
- 14 L: 8/22 kg
- 22 L: 9/31 kg
- 44 L: 11/55 kg

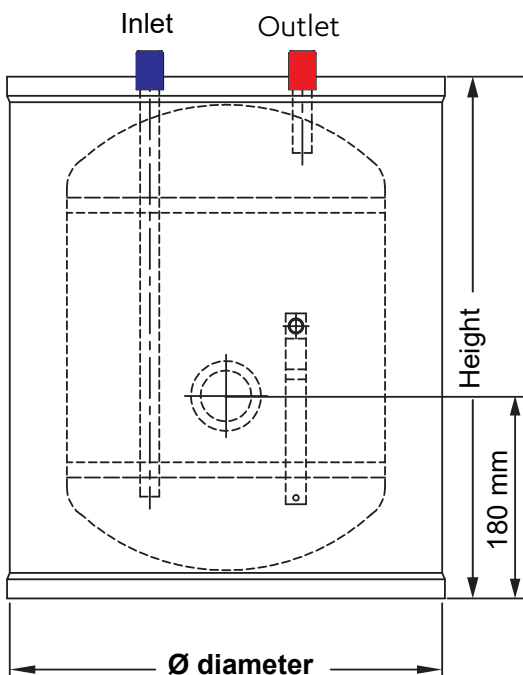

1/2 " BSP male (9 L, 14 L, 22 L)
3/4 " BSP male (44 L)

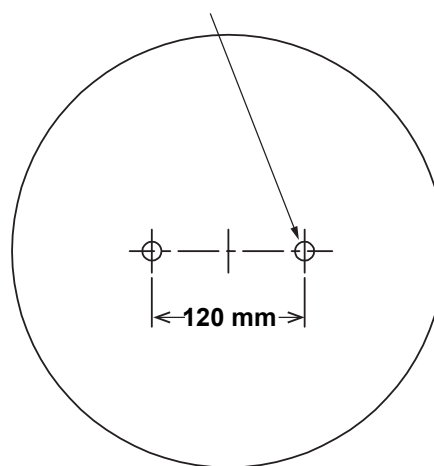

Cylinder size	Diameter	Height	Element rating
9 L	Ø 340 mm	315 mm	1 kW
14 L	Ø 340 mm	420 mm	1 kW
22 L	Ø 340 mm	575 mm	1 kW
44 L	Ø 445 mm	585 mm	2 kW

Specification summary

low pressure standard copper, and wetback

Suitability

- Low pressure indoor applications
- Left, right, or bottom plumbing connections

Not suitable as a pool or spa heater.

The system should be located and arranged so as to achieve the closest proximity to water draw off points.

Construction

- High grade copper inner cylinder
- Galvanised steel outer casing
- CFC-free polyurethane foam insulation (ODP free)

Operating pressures

Maximum inlet pressure = 76 kPa

Maximum working pressure = 76 kPa

Element

Low watt density nickel plated copper, 1.25 " BSP boss.



Standard thermostat

7 " Cotherm probe 20 A over-temperature thermostat, manually resettable at 85 °C.

Wetback thermostat

7 " Cotherm probe 20 A (no over-temperature) thermostat.

Weights

	empty	full
• 44 L:	11 kg	55 kg
• 90 L:	16 kg	106 kg
• 135 L:	21 kg	156 kg
• 180 L:	26 kg	206 kg
• 225 L:	31 kg	256 kg

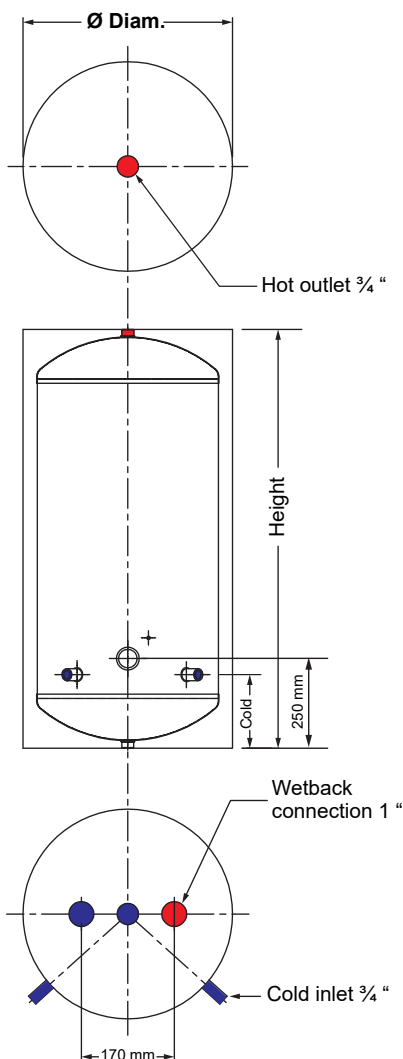

Size	Diam.	Height	Height to cold	Centres of wetback ports	Wetback connection
All dimensions are in mm.					
44 L	Ø 445	585	120	N/A	N/A
90 L	Ø 430	1115	150	N/A	N/A
90 L	Ø 500	820	175	N/A	N/A
90 L	Ø 530	745	175	N/A	N/A
135 L	Ø 470	1315	180	170	1 "
135 L	Ø 500	1165	175	170	1 "
135 L	Ø 510	1170	175	170	1 "
135 L	Ø 530	1055	175	170	1 "
135 L	Ø 540	1035	200	170	1 "
135 L	Ø 550	980	180	170	1 "
180 L	Ø 510	1495	175	170	1 "
180 L	Ø 530	1370	175	170	1 "
180 L	Ø 540	1320	200	170	1 "
180 L	Ø 550	1265	180	170	1 "
225 L	Ø 550	1540	180	170	1 "

Plumbing setup

Cylinders should be installed in accordance with G12/AS1. For servicing and maintenance, please allow sufficient room for access to covers and valves.

Plumbing setup for a low pressure cylinder - valve vented

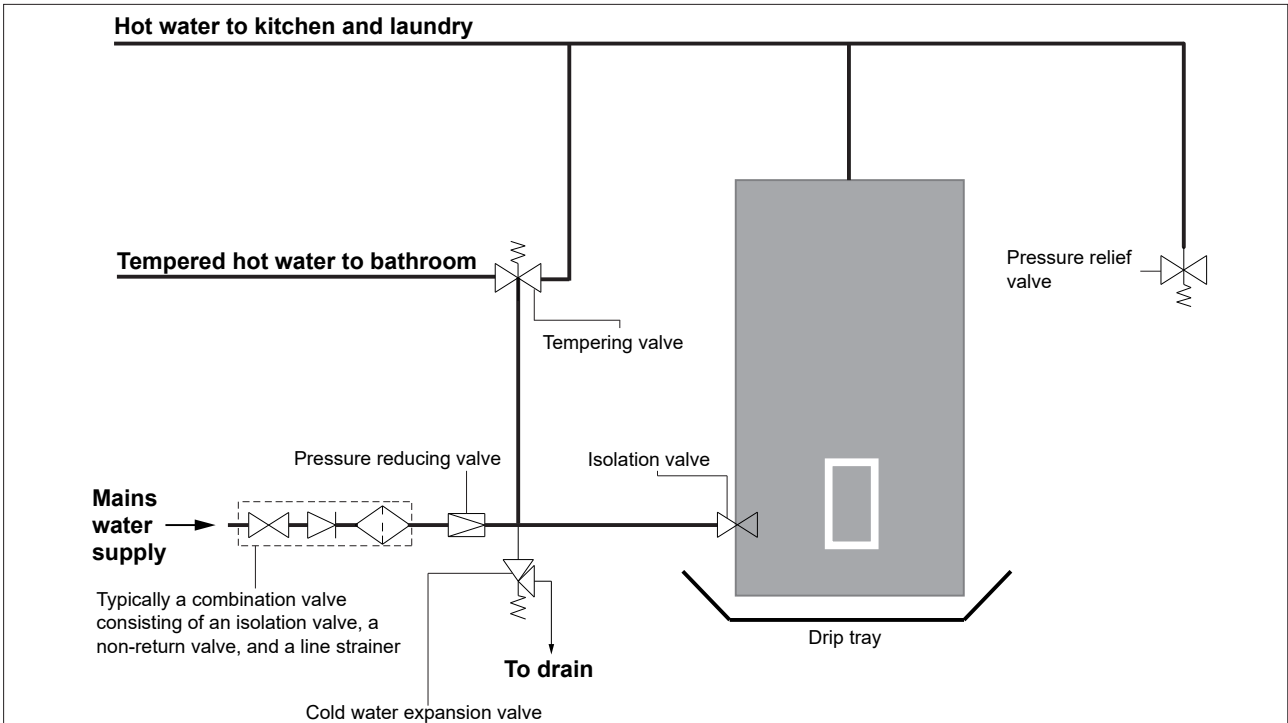

Plumbing setup for a low pressure cylinder - open vented

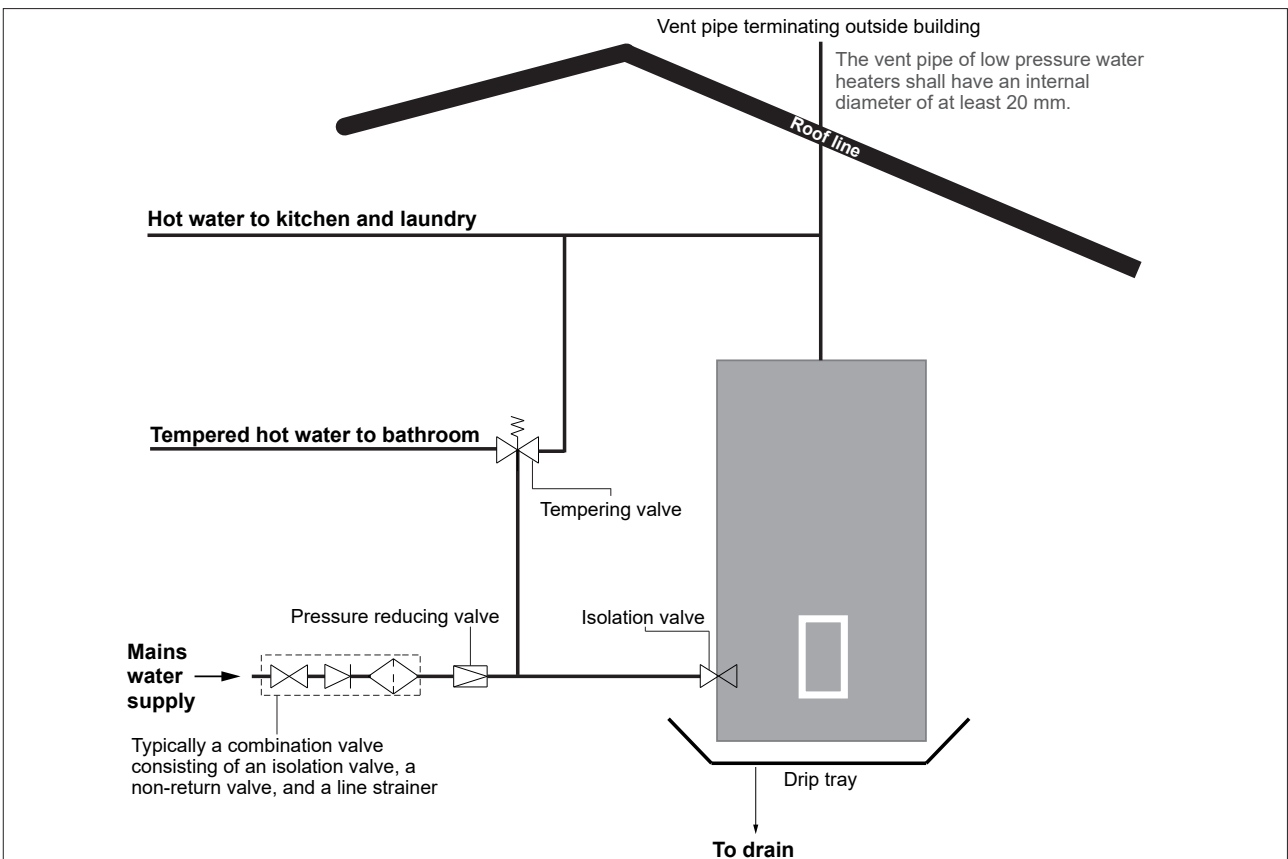

The appliance is not intended to be connected by a hose-set.

Plumbing setup for a low pressure copper cylinder with a wetback

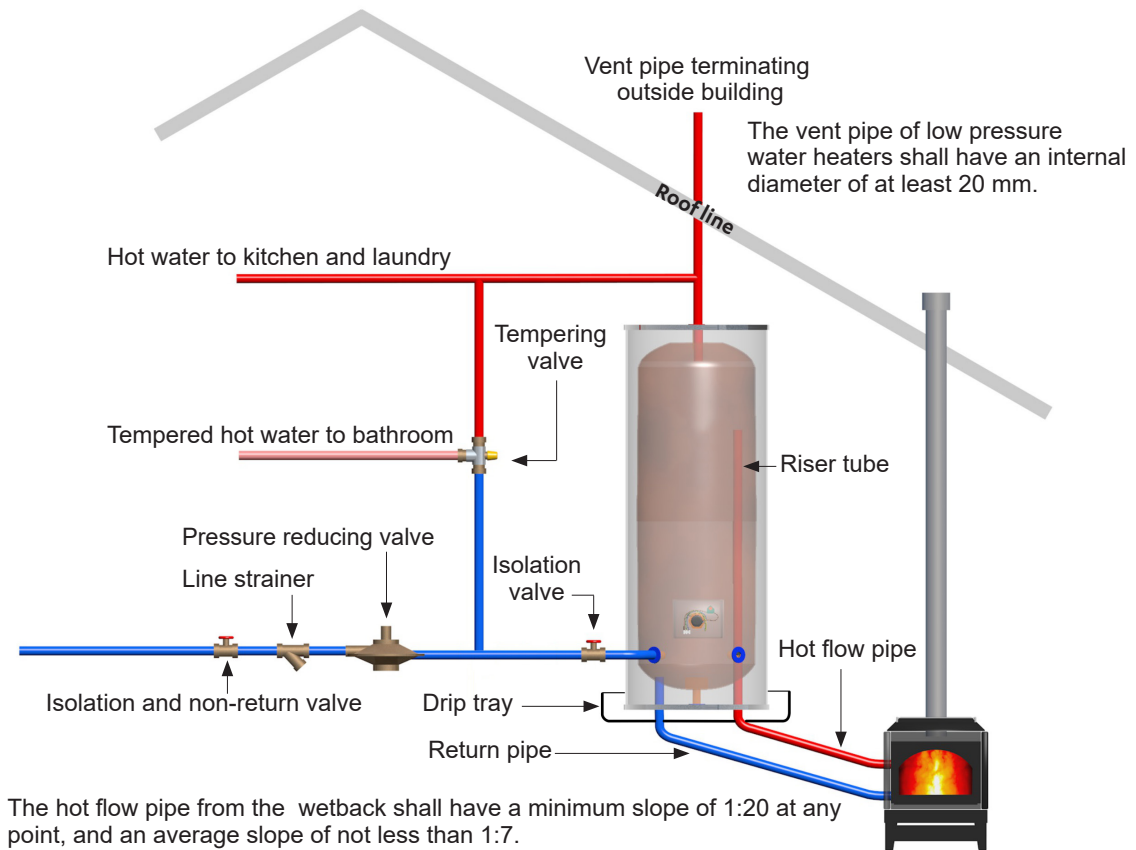

Base requirements

Tanks should be installed on a flat level base of sufficient strength to support the weight of the water heater when full.

The water heater must also be suitably restrained against seismic activity, 'G12/AS1 Figure 14' details an acceptable method of restraint.

Drip tray/catch pan (MUST be fitted)

The Rinnai warranty does not cover any consequential loss from leaks to the cylinder, so it's important a suitably drained drip tray/catch pan is fitted as per AS/NZS 3500.4:2015 5.4 and G12/AS1 6.11.3

Pipe work

It is the installer's responsibility to adequately size the distribution pipe work in a property to ensure sufficient performance from all outlet fittings. Water pipe sizing should be performed in accordance with AS/NZS 3500.4 and/or G12 AS1. Pipe sizing and valve selection must be performed to allow for the water supply pressure.

A drain off tap or line must be fitted to the inlet of the water heater.

All hot water pipe work should be insulated with polythene foam or equivalent insulation to optimise performance and energy efficiency.

To prevent damage to the water heater when attaching pipe clips or saddles to the jacket, it is recommended that self drilling screws with a maximum length of 12 mm are used. If drilling is required take extreme care not to penetrate the inner cylinder.

Storage and delivery temperatures

Storage temperature

To meet the New Zealand Building Code requirement¹ to disinfect water for legionella bacteria, the cylinder thermostat has been set to 65 °C.



Thermostat settings must only be adjusted by an electrician or other suitably qualified tradesperson. The access cover to the element and thermostat must only be removed by an electrician or other suitably qualified tradesperson.

Sanitary fixtures delivery temperature

Water temperatures over 55 °C can cause severe scalds. Local regulations must be considered regarding temperature limitations of hot water supplied to areas used primarily for personal hygiene. The temperature is limited to 45 °C for early childhood centres, schools, nursing homes or similar facilities and 55 °C for all other buildings. To comply with these requirements, a temperature limiting device, such as a tempering or thermostatic mixing valve will be required on all installations.

¹ Clause G12.3.9, Acceptable Solution G12/AS1 6.14.3

Water quality

The water quality of most public supplies, and from bore wells is generally suitable. Refer to the water quality parameters in the warranty section of this guide for further information.



Blue water

Blue water is a result of biofilms being formed which corrode the copper to feed the microorganisms, producing copper carbonate and hydroxyis in the water. The major cause is the lack of chlorine in the water to destroy the microorganisms, but it is also effected by the pH value. In instances of blue water, it is recommended that expert advice on chlorine control is consulted, and the pH of the water is tested. The recommended pH scale is between 8.0-8.3.

Pitting corrosion

Pitting corrosion occurs when the protective coating does not form on the interior of the hot water tank. The main cause of this is the failure to hold the pH at 8.0-8.3 for the period of four months immediately following the tank installation. Pitting corrosion may also occur, in the form of deposit attack, if foreign or corrosion products have been allowed to enter the water supply. In the instances of deposit attack it is recommended filtration experts are consulted.

Electrical supply and connections

The electrical connection must be carried out by a qualified person in accordance with NZ Electrical Regulations. The water heater must have the heating element connected to an independent, fused, AC 230 V 50 Hz power supply with an isolating switch installed at the switch board. Disconnect all power prior to installation and commissioning.

- The water heater must be filled with water prior to connection to the power supply
- Household wiring to the heater must be capable of withstanding the appliance load
- Fixed wiring must be protected from contact with the internal hot surface of the water heater

Electrical access is via a hole in the element cover for mounting with an approved electrical conduit gland. For entry to the element cover remove the two fixing screws.

Connect all LIVE, NEUTRAL and EARTH wires in accordance with the wiring diagram. Inspect and ensure all wiring links are secure prior to fixing the access cover and turning the power on.

To ensure the over-temperature and energy cutout is set press the 'reset' button on the thermostat (not applicable for wetback tanks)

The appliance is intended to be connected to cables of fixed wiring which has a cross-sectional area of 1.5 mm² - 2.5 mm².

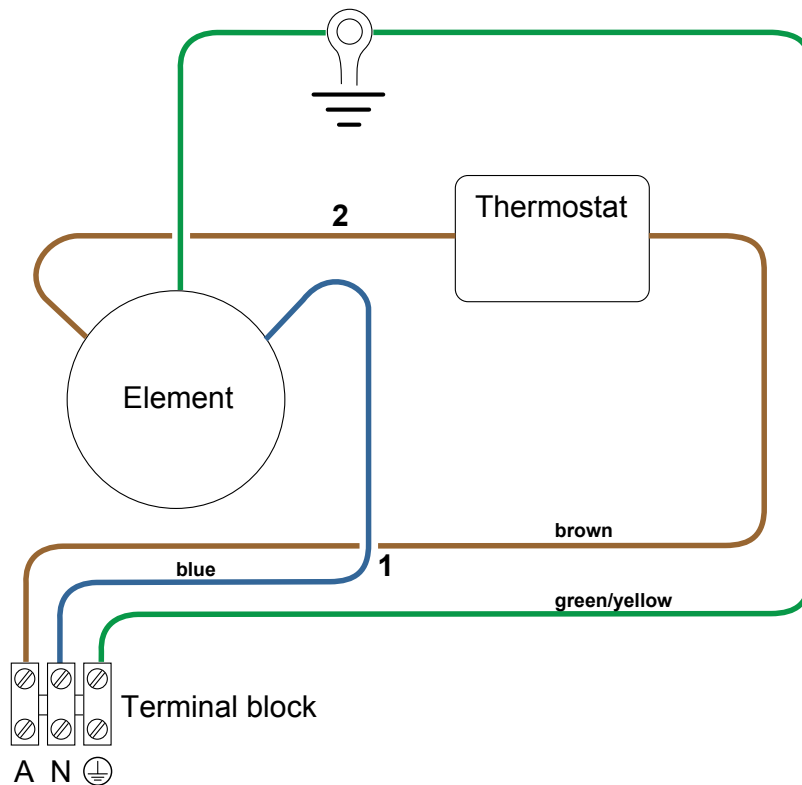

1	Wiring loom main low pressure	brown, green/yellow, blue	20080
2	Link wire brown low pressure	brown	20081

Valves and fittings

Valves with pressure ratings other than those listed in this manual must not be used.

Fittings supplied with the tank

Two brass plugs, to plug unused connections, are packaged in a plastic bag inside the element cover, and a copper riser tube (for wetback tanks) is supplied.

Commissioning

Commissioning and draining activities must be carried out by an authorised person.

To fill and turn on the water heater

1. Open all hot water taps in the house including the shower.
2. Open the cold water isolation valve to the water heater. Air will now be forced out of the taps.
3. Close each tap when water runs freely without air bubbles.
4. Check all plumbing connections and pipe work for water leaks.
5. Switch on the electric power supply.

To turn off the water heater

It may be necessary to turn off a water heater after installation and commissioning, for example during building activities or if the premises are vacant.

1. Switch off the electricity supply at the isolating switch to the water heater.
2. Close the cold water isolation valve at the inlet to the water heater.

To drain the water heater

1. Turn off the heater, refer above.
2. Open all the hot water taps and then for valve vented (closed) installations, open the union at the top outlet to allow air into the tank and water to drain (ensuring no damage will occur from the discharged water).

Undersink models - drain for service

Use the following procedure to drain undersink models:

1. Isolate the unit from the water mains.
2. Disconnect inlet port from cold water supply.
3. Open the hot water tap connected to the unit outlet.
4. Feed a 10-12 mm flexible hose into the inlet port of the unit. Feed the hose until it reaches the base of the cylinder.
5. Siphon the water out of the cylinder into a suitable drain or collection vessel.
6. Once the cylinder is drained remove siphon tube, disconnect hot water outlet connection, and remove cylinder.

Limited Warranty

Rinnai brings you peace of mind with a:

5-year warranty



This warranty applies to **Rinnai Low Pressure Copper indoor cylinders** only.

All terms of the warranty, subject to the conditions below, are effective from the date of first installation. Proof of purchase and installation date will be required at the time of any warranty claim. Where the date of installation is not known or cannot be proven the warranty will commence one month after the date of manufacture—refer to the data label on the cylinder. This warranty is only valid within the country of purchase.

		Residential application	Commercial application
Cylinder only		5 years	1 year
	Labour	1 year	1 year
All other parts supplied by Rinnai (thermostats, elements, seals etc.)	Parts	1 year	1 year
	Labour	1 year	1 year

Single residential application warranty

A residential application is defined as an installation where the water heater, with the thermostat set below 85 °C, delivers hot water to a single family residential dwelling, not used for commercial purposes.

Examples where a residential dwelling is used for commercial purposes; hair salon, catering kitchen, communal care facility etc. These installations would be considered commercial applications. An exception would be an accommodation business such as a motel, where the water heater serves the equivalent of a single family dwelling, this would be a residential application.

Commercial application warranty

For constant use applications such as, but not limited to these, underfloor heating and circulating ring mains. The cylinder must be sized and installed according to written guidelines from Rinnai.

General warranty terms

Rinnai reserves the right to make modifications and change specifications and its parts without notice.

For the purposes of the Consumer Guarantees Act 1993, Rinnai only guarantees the availability of repair facilities and spare parts for the express warranty periods recorded in the Rinnai warranty summary table.

If the cylinder is being acquired for personal, domestic or household use, this warranty does not limit any consumer rights or guarantees that may apply under the Consumer Guarantees Act 1993. If the product is being acquired for the purposes of a business, the provisions of the Consumer Guarantees Act 1993 do not apply and no other warranties (either express or implied by law) apart from those stated in this warranty apply.

Warranty terms and conditions

1. All terms of this warranty are effective from the date of first installation. The attending service person reserves the right to verify this date.
2. All Rinnai cylinders must be installed, commissioned, serviced, repaired and removed in accordance with the manufacturer's installation instructions, local regulations, and municipal building codes by persons authorised to do so.
3. All Rinnai cylinders must be operated and maintained in accordance with manufacturer's instructions.
4. The warranty applies only to the components supplied by Rinnai. It does not apply to components supplied by others, such as, but not limited to these, isolating valves, electrical switches, pipe work, electrical cables, and fuses.
5. Where the cylinder has not been sited in accordance with the installation instructions or installed such that normal service access is difficult, a service charge will apply. If at the discretion of the attending service person the installation is deemed illegal or access is dangerous, service will be refused. Any work required to gain reasonable access to the cylinder will be chargeable by the attending service person (for example, removal of cupboards, doors, walls, or the use of special equipment to move components, but not limited to these).
6. The cylinder warranty is for the period indicated in the summary table. Where the cylinder and/or part is replaced under warranty the balance of the original warranty will remain effective.
7. Rinnai reserve the right to transfer functional components from defective water heaters if they are suitable.
8. Rinnai reserve the right to have the installed product returned to the factory for inspection.
9. Where the cylinder is installed outside the metropolitan area or further than 40 km from a Rinnai authorised service centre, travel costs shall be the owner's responsibility.
10. Rinnai reserves the right to replace the cylinder for another type if upon inspection it is deemed another cylinder of a different construction is more suitable.

Warranty exclusions

The following exclusions may cause the warranty to become void and will result in a service charge and costs of parts (if required).

1. Accidental damage and acts of God.
2. Failure due to abuse or misuse, improper maintenance or improper storage.
3. Failure due to incorrect or unauthorised installations.
4. Failure or damage caused by alterations, service or repair work carried out by persons other than those authorised by Rinnai.
5. Where the cylinder has failed directly or indirectly as a result of poor water quality outside the limits specified and/or used with bore or tank water.

TDS (Total Dissolved Solids)	Total Hardness CaCO ₃	Dissolved (free) CO ₂	Langelier Index
Up to 600 mg/L or ppm	Up to 200 mg/L or ppm	Up to 25 mg/L or ppm	Between -1.0-0.8

6. Where it is found that there is no fault with the cylinder and the issue is related to the installation or is due to power failure.
7. Subject to any statutory provisions to the contrary, Rinnai does not accept:
 - a. liability for consequential damage or any incidental expenses resulting from any breach of the warranty.
 - b. claims for damage to building or any other consequential loss either directly or indirectly due to leaks or any other faults.

Warranty examples in the real-world

We understand warranty information can be confusing. To help clarify what this means in the real-world we have developed some residential application scenarios to clarify what would fall within warranty and what wouldn't.

Scenario	Age of part/ cylinder	Within warranty	
Faulty thermostat	10 months	Yes	All costs covered by Rinnai.
Faulty element	3 years	No	All costs covered by the owner.
Cylinder leaks as a result of a faulty inner cylinder and causes damage to carpets and flooring	11 months	Yes/No	Cost of cylinder replacement covered by Rinnai. Consequential loss, damage to carpets and flooring, is not ¹ .
Cylinder fails	4 years	Yes	Cost of cylinder replacement covered by Rinnai. The cost of removal of the cylinder, re-installation, and labour costs are the responsibility of the owner.

¹ Consequential losses

All cylinders are required to be installed with a drip tray, this is a mandatory requirement of the installation. If damage is caused by a leaking cylinder that has not been installed with a drip tray the owner can seek compensation through the installer or consider claiming on insurance.

Purchase details

Record your purchase details below

ATTACH YOUR PROOF OF
PURCHASE HERE: 

Retailer: _____

Retailer address: _____

Date of purchase: _____

Product details: _____

Please keep these details in a safe place for future reference.

Register your Rinnai cylinder online at www.rinnai.co.nz/register/ for service reminders, product updates and special offers—you can unsubscribe at any time.

Installer details

Company name: _____

Installer name: _____

Address: _____

Phone: _____

Mobile: _____

Signed: _____

Date: _____

Rinnai.co.nz

Tel: 0800 746 624
<http://www.youtube.com/rinnainz>
<http://facebook.com/rinnainz>

20733-H: 08-20